



MATERIAL HANDLING SOLUTIONS THAT WORK

Tel: (905) 624-6499 • Fax: (905) 624-0228 • www.weconsystems.com

BELT ON ROLLER CONVEYOR OWNERS MANUAL

Table of Contents

INTRODUCTION	3
SAFETY WARNINGS	5
BEFORE STARTING MAINTENANCE	5
DURING MAINTENANCE.....	5
AFTER MAINTENANCE	5
EQUIPMENT DESCRIPTION.....	7
EQUIPMENT DESCRIPTION.....	7
INSTALLATION INSTRUCTIONS	9
POSITION AND ALIGNMENT	9
SUPPORT ASSEMBLY	10
CONVEYOR FRAME INSTALLATION.....	11
STRAIGHT NOSE-OVER BED.....	11
POWER FEEDER.....	11
END DRIVES	12
CENTRE DRIVES.....	12
INSERTING ROLLERS INTO FRAME.....	12
BELT INSTALLATION	13
PREPARING UNIT TO RUN	14
BELT TRACKING AND TIGHTENING	15
MAINTENANCE.....	16
MECHANICAL MAINTENANCE.....	16
ELECTRICAL MAINTENANCE.....	17
TROUBLE SHOOTING GUIDES.....	18
MOTOR AND GEAR REDUCER	18
CHAIN AND SPROCKETS	18
ELECTRICAL.....	19
BELT.....	20
PARTS GUIDE	21
DRIVE PULLEY	21
IDLER PULLEY	21
8” DRIVE PULLEY (FOR CENTRE DRIVE ASSEMBLY).....	22
TAKE UP ROLLER (FOR CENTRE DRIVE ASSEMBLY).....	22
SNUBBER ROLLERS (FOR BELT ON ROLLER DRIVE BED).....	22
CARRIER ROLLERS.....	22
BELT RETURN ROLLERS.....	23
BEARINGS	23
BELTING / LACING.....	23
DRIVE TRAIN PARTS	24
MOTOR / REDUCER / SPROCKETS	24
SUPPORTS	27
FORMED ANGLE GUARD RAILS	27
TOUCH-UP PAINT.....	27

THIS PAGE LEFT BLANK INTENTIONALLY

BELT ON ROLLER INDUSTRIAL CONVEYORS

INTRODUCTION

Thank you for purchasing a Belt On Roller Conveyor from Wecon Systems. This model is made of the finest materials available and is manufactured in Canada by skilled craftsmen. The conveyor is very easy to operate and to maintain, but we recommend that you read this owner's manual thoroughly before using the conveyor.

This manual provides installation instructions, start-up procedures, safety tips, a parts list and information regarding preventative maintenance, lubrication and troubleshooting. This conveyor is durable and has been designed for a long service life.

THIS PAGE LEFT BLANK INTENTIONALLY

SAFETY WARNINGS

WARNING: DO NOT ATTEMPT MAINTENANCE ON ANY CONVEYOR WHILE IT IS IN OPERATION.

BEFORE STARTING MAINTENANCE

- Read and understand instruction manual and be aware of all warning stickers.
- Know where the emergency stop buttons are located.
- Know or have quick access to emergency telephone numbers in the unforeseen event that an emergency should arise.
- Maintenance functions are to be performed while the conveyor is off. The main power disconnect switch to the conveyor shall be locked out in accordance with proper written lockout procedures. This will prevent anyone from applying power to the system while maintenance personnel are at work.
- NEVER work on a conveyor while it is running unless the maintenance procedure requires the equipment to be running. When a conveyor must be operating to perform the maintenance, allow only properly trained maintenance personnel to work on the conveyor.
- Wear safety glasses when in the proximity of the conveyor.
- NEVER allow personnel with long hair near the conveyor without the use of a protective hair net.

DURING MAINTENANCE

- Do not wear loose clothing, ties or jewelry while servicing or performing maintenance on any conveyor equipment.
- Be aware of hazardous conditions, such as sharp edges and protruding parts.
- When using hoists, cables or other mechanical equipment to perform maintenance, use care to not damage conveyor components.
- Keep area clean. Clean up lubricants and other materials before starting conveyor.

AFTER MAINTENANCE

- Before starting the conveyor after any maintenance has been completed, walk around the equipment and make certain all safety devices and guards are in place, pick up tools, maintenance equipment and clear any foreign objects from equipment.
- Make certain all personnel are clear of the conveyor and made aware that the conveyor is about to be started.
- Only authorized personnel should be permitted to start any conveyor following maintenance or emergency shut-off.
- Never place any part of your body in or on any part of this conveyor while in operation.
- Do not allow anyone to stand on the conveyor.
- Do not allow horseplay around the conveyor.
- Do not remove guards, perform maintenance or clear obstructions without first locking out the main power disconnect switch.

PLEASE RECOGNIZE ALL WARNING STICKERS AND OBEY ANY SAFETY INSTRUCTIONS. WARNING STICKERS ARE PLACED ON THE EQUIPMENT FOR YOUR SAFETY – PLEASE DO NOT REMOVE THEM. CONDITIONS DO EXIST ON ANY CONVEYOR THAT CAN CAUSE INJURY OR DEATH TO PERSONNEL. NO MANUAL CAN COVER ALL THE HAZARDOUS CONDITIONS THAT MIGHT DEVELOP. ALL PERSONNEL INVOLVED IN THE OPERATION OF ANY CONVEYOR EQUIPMENT SHOULD BE CONSTANTLY AWARE OF ANY UNSAFE CONDITIONS AND USE ALL POSSIBLE CARE, ALONG WITH COMMON SENSE AND STRICT ADHERENCE TO ACCEPTED SAFETY STANDARDS TO AVOID INJURY.

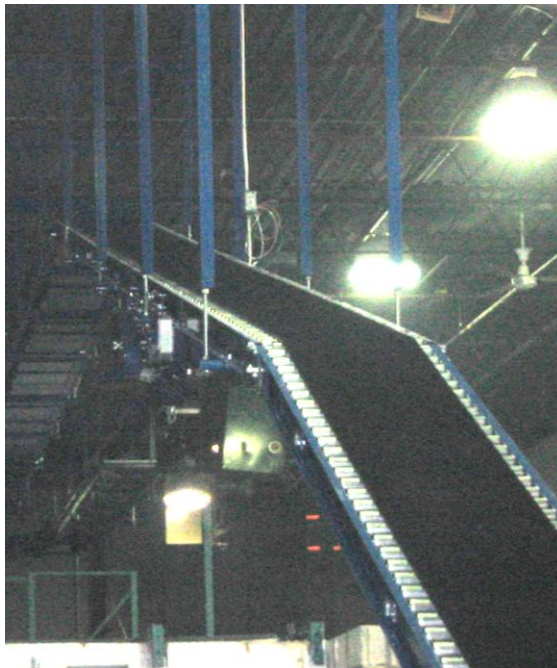

INCLINE BELT ON ROLLER CONVEYOR

IMPORTANT

Wecon Systems does not warrant parts or components not manufactured by Wecon Systems. The manufacturers of electric motors and controls, air and hydraulic components and certain other items extend warranties, which may or may not be similar to that of Wecon Systems manufactured equipment. Defective material of this type should be reported by the customer to Wecon Systems whose sole responsibility is to notify the vendor of the defective material for action. Wecon Systems will not be responsible for units that have been tampered with or disassembled by anyone other than the authorized representative of the respective manufacturer.

EQUIPMENT DESCRIPTION

EQUIPMENT DESCRIPTION

Belt on roller conveyors operate by pulling a belt over the top of a series of carrier rollers positioned high within a metal channel frame. Products are conveyed directly on the surface of the belt.

Belt on roller conveyors provide smooth, continuous flow of product under positive control. They can be used in horizontal applications, but are commonly used to change elevations by inclining or declining. The carrying surface of a belt on roller conveyor facilitates the conveyance of a variety of loose and irregularly shaped products. These conveyors are available in 4" or 8" carrier roller centers to allow for as few or as many rollers as required to convey the specified product. They can provide a braking surface to start accumulation when stopped, gap the product with a speed change, or index the product by starting and stopping.

Belt on roller conveyors provide much less belt friction than sliderbed conveyors, enabling longer runs without increasing the drive size.

Wecon conveyors use a number of standard drive configurations. Centre drives are capable of two-way operation and end drives are capable of one-way operation only.

Belt on roller conveyors are available in standard nominal bed widths of 12", 18", 24", 30" and 36".

Various accessories are available such as belt variations, power or gravity feeders, nose overs, variable speed drives, trussing and guardrails.



8" CENTER DRIVE

Belt On Roller Bed Sections – Bed sections are welded construction. The carrier rollers are positioned high within the 5-1/2" deep side channels providing a surface for the belt to travel.

End Pulleys – consist of two types:

1. Drive Pulley – used in conjunction with end drives only.
2. Idler Pulley – used on both end and centre drives.

Take-up Assemblies – consist of two types:

1. End Take-up Assembly – used on the idler end of the conveyor.
2. Centre Take-up Assembly – used as part of the centre drive assembly.

Drives – Are the power source that moves the belt.

Consisting of two types:

1. Centre Drive – can be used for one-way or two-way operation.
2. End Drive – can only be used for one-way operation.

Either centre or end drives can be used depending on the application. Standard drives have fixed speeds. Variable speed drives are available as an option.

Nose-Over-Splice – Pair of adjustable splice plates, used as bed connections, with rollers to allow change of belt plane.

Power Feeder – Moves the product onto or off an incline unit. Normally it is used at the lower end of an incline unit. A feeder drive pulley takes the place of an end pulley and is driven by the main unit belt. A chain connects the drive and drive pulleys to supply power to run the feeder belt.

Belt – Carries the product. They are available in many top and bottom surface variations. Belt width is 4” narrower than bed width for conveyors under 24” wide and 6” less for wider units. The belt is laced together to provide a continuous loop. Take out sections are available and can be provided as an option.

Supports – May be mounted to the floor or the ceiling. Numerous width and height combinations are available.



STANDARD SUPPORT



HEAVY DUTY SUPPORT

Trussing – A means of supporting long spans. It adds rigidity to the conveyor. Trussing is used when more practical than supports.

Guard Rails – Formed angle guard rails keep the product contained on the conveyor. All overhead applications require the installation of guard rails to help prevent the conveyed product from falling from the conveyor to the area below.

INSTALLATION INSTRUCTIONS

POSITION AND ALIGNMENT

Proper mechanical installation is vital for the equipment to operate as described. Our installation standards show the importance that Wecon places on a quality installation.

Installation Standards

- **In General:**
The following standards, where applicable, will be used as guidelines by Wecon approved installers.
- **Dimensional Reference Points:**
The location of each conveyor in the system will be determined by establishing a reference point to the center of each conveyor from the fixed building column lines as indicated on approved general arrangement drawings.
- **Level and Elevations:**
Conveyors will be installed in accordance with the elevations shown on the layout drawing(s).
After the first elevation is established, the elevation of all other points will be related to this first point. The practice of dimensioning elevations from the floor at each point of support will not be followed. When the floor level changes significantly, such as the system going to an upper or lower floor, or into another building or room, a new elevation will be established from the first floor at that point. This new elevation will then become the reference point for subsequent elevations.
- **Standards For Floor Mounting:**
Anchoring will be accomplished by drilling into the floor and inserting a suitable anchor bolt in an approved manner in accordance with the manufacturer's instructions.
Drive and intermediate stands will be anchored with 3/8" diameter minimum bolts, one in each leg.
Explosive type anchors will not be used. Adhesive or specialized anchors will be used only when specified.

Floor Mounted Units

- Use a plumb line to align the centre line of each conveyor section to the chalk line.
- Set height of unit.
- Adjust the conveyor both lengthwise and diagonally using a level.

NOTE: Beds must be level from side to side to prevent the possibility of a mis-tracking belt.

Beds and Supports

Beds are designed to accommodate both intermediate and end bed applications. Belt on roller conveyors are available with carrier rollers on 4" or 8" centers. End beds include a 4", 6" or an 8" diameter end pulley or drive roller.

SUPPORT ASSEMBLY

Supports are fastened to the bottom flange utilizing holes designed into each bed section. Supports can be installed directly under a bed joint to support two adjacent bed sections. For single or end bed applications, supports can be mounted in the first available set of holes at the charge and the discharge ends of the conveyor. Mounting a support can be accomplished by either lifting the bed section into position onto a support or attaching the support to a bed section prior to lifting it into position. After the conveyor has been aligned and leveled, anchor the supports to the floor in an approved manner in accordance with the anchor bolt manufacturer's instructions.



HD SUPPORT MOUNTED ON END



HD SUPPORT MOUNTED ON JOINT

CONVEYOR FRAME INSTALLATION

It is recommended that only trained personnel install or service this equipment.

Wecon BELT ON ROLLER conveyors are shipped on skids, generally, not exceeding 4000 pounds, for lift truck unloading and handling. The skids may also be handled with a crane if one is available. If a crane is utilized, ensure the operator is certified in the competency of its operation. Each skid will vary in width, length and height depending upon the style of product purchased.

The conveyor frames, supports, rollers and accessories should be thoroughly inspected before proceeding with the conveyor installation. Upon delivery, be sure to check the following items very carefully:

- The alignment of frames, to ensure horizontal and parallel orientation.
- The equipment to ensure there is no visible damage to the frames or rollers.

STRAIGHT NOSE-OVER BED

- One nose-over splice plate assembly must be attached to each end of the straight nose-over bed.
- Fasten splice plate assemblies to the ends of the straight nose-over sections using the slotted holes provided. Fasteners should be finger tightened only to allow for positioning of the bed.
- Set proper angle of bed, dividing total change in plane angle by two to obtain set angle for the splice plate assemblies.
- Tighten bolts.

POWER FEEDER

- Turn power feeder upside down and fasten the floor supports to the bed.
- Turn power feeder right side up and attach take-up pockets to the charge bed on the main conveyor using the hardware supplied.
- Check to ensure the drive pulley is square to the bed on the main conveyor. Make adjustments if necessary to ensure proper tracking of the belt.
- Align and level power feeder.
- Install chain and chain guard.

END DRIVES

Position End Drive unit as follows:

- On a horizontal conveyor used for one-way operation, the drive is always located at the discharge end of the conveyor.
- Prior to start up, check and verify the reducer has the correct level of oil and that breather plugs (if required) are installed correctly before operating the motor.

NOTE: End Drives are specifically designed for one-way operation and not for two-way applications.

CENTRE DRIVES

Position Centre Drive in unit as follows:

- Optimum performance will be achieved when the drive is located where the minimum length of tight belt is between the load and drive pulley.
- For horizontal two-way operation, the Centre Drive should be located near the centre of the conveyor where loads will be approximately equal in each direction of travel. For applications where loads will be typically heavier for a particular direction of travel, the Centre Drive should be located proportionately closer to the discharge end.
- Drive should be located as close as possible to the high end of an incline conveyor so that the minimum length of tight belt is between load and drive pulley.
- Prior to start up, check and verify the reducer has the correct level of oil and that breather plugs (if required) are installed correctly before operating the motor.

INSERTING ROLLERS INTO FRAME

- Rollers are inserted into the beds by pushing the spring loaded end of the axle. The protruding axle is positioned into the hex hole on one side of the conveyor frame. The roller is then aligned to the hex hole on the opposing side channel and the tension on the axle is released allowing the axle to return to its stationary position locking the roller in the bed frame.
- Rollers are removed from the bed frames by reversing the procedure.

BELT INSTALLATION

- Ensure all surfaces that the belt will touch are free from oil and other debris.
- Check to ensure the return belt path is clear and clean.
- Check to ensure the belt return rollers turn and they are set in the centre position in their slots.
- Ensure the take-ups are set at their minimum.

**4" END ASSEMBLY**

- Place the roll of belt to be used on the conveyor at the discharge end.
- Ensure the load carrying surface of the belt is facing upwards as the end of the belt is being pulled off the roll and along the conveyor to the end pulley.
- Pull belt down around the end pulley and thread the end back along the path over the belt return rollers as required.
- Refer to appropriate figures for the path of the belt through the drive.

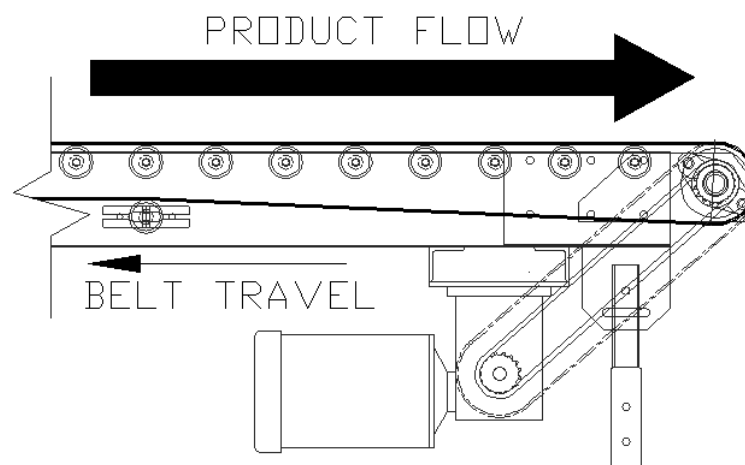
**BELT PATH FOR END DRIVE**

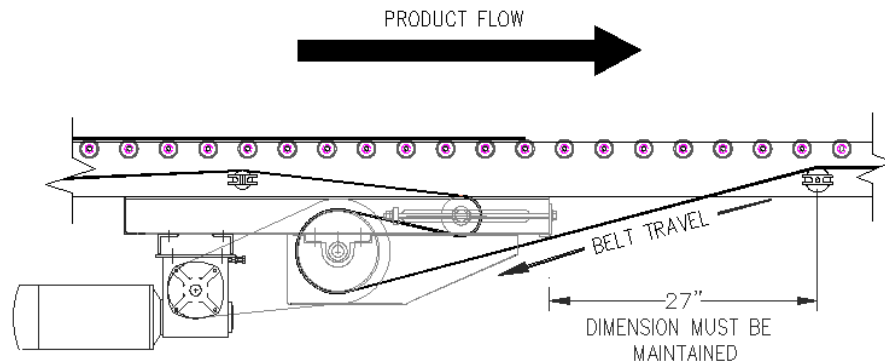

BELT PATH FOR CENTER DRIVE

Note: the location of the center drive is of the utmost importance to ensure proper tracking of the conveyor belt. The take up frame of the center drive must be positioned to maintain a 27" dimension from the upstream snubber roller in the direction of product travel. The second snubber roller is located towards the charge end of the bed 60" from the original roller. The position of these snubber rollers ensure the belt is unobstructed while travelling through the center drive. Drive beds are designed to uphold these dimensions. Constraints under certain circumstances may necessitate the movement of the center drive within a bed. Any coincidental movement of the drive must also include the relocation of the snubber rollers to maintain conformity of these dimensions.

- Route belt around remaining end pulley and bring ends of belt together on top of bed surface.
- Clamp one end of the belt to the bed.
- Use belt puller to bring ends together if required.
- Mark, cut and lace belt if required.
- With belt ends pulled together and lacing meshed, install lacing pin.

PREPARING UNIT TO RUN

- Ensure the conveyor path is free from oil, debris and other foreign objects.
- Check to ensure the motor is properly wired for correct rotation with respect to the direction of belt travel.
- Adjust take-ups to remove any slack from the belt. Ensure take-up pulleys are aligned and square to the bed frame.
- Ensure all personnel are clear, then run unit and observe belt tracking.

B E L T T R A C K I N G A N D T I G H T E N I N G

- With unit running, observe belt travel over the bed surface and through all components.
- Maintain pulley squareness to the frame by adjusting evenly at each end.
- End pulley adjustment is used only as a last resort. Never use the drive pulley or drive take-up pulley for belt tracking.
- Ensure the belt return rollers are square to bed by checking that the shafts are in the middle of the slots.
- When using the belt return rollers for belt tracking, **“The belt moves towards the side of the roller it touches first.”**
- If belt wanders off centre and then returns to the centre during a complete rotation, no adjustment for tracking is necessary. This kind of mis-tracking is caused by a lengthwise chamber in the belt which may correct itself with continued use.
- If belt wanders off centre within a particular bed section, turn off drive then check bed section for alignment and squareness.
- If mis-tracking occurs at an end pulley, square end pulley to the bed frame.
- Measure distances between the pulley shaft and the end of the bed. Measurements should be equal at both ends of the pulley. If not, the end pulley is not square to the bed.
- To adjust squareness of an end pulley, loosen the jam nut and turn the adjusting screw as needed to move one end of pulley shaft until measurements are equal.
- Tighten jam nuts to secure adjustment.
- If mis-tracking continues to occur at an end, drive or take-up pulley after adjustments have been made in accordance with the preceding steps, a roller or pulley up stream from the mis-tracking area can be adjusted to centre the belt.
- Run conveyor with a moderate load of product on belt and check for proper belt tension.
- If belt does not slip on the drive pulley and is reasonably slack between the belt return rollers, belt tension is correct.
- If belt slips on the drive pulley, tighten belt.
- **Do not over tighten belt, as parts can be damaged or service life can be significantly reduced.**
- Loosen jam nuts and turn adjusting screws at the ends of take-up pulley, turning alternately and equally a few turns at a time, to move take-up pulley away from drive pulley.
- When take-up pulley has been moved enough to stop belt from slipping on drive pulley, tighten jam nuts on adjustment screws to lock setting.
- Check to ensure supports are level.
- Check belt return rollers in the bottom of belt on roller bed section. If belt is running to one side, loosen and adjust upstream roller.

MAINTENANCE

WARNING: DO NOT ATTEMPT MAINTENANCE ON ANY CONVEYOR WHILE IT IS IN OPERATION.

MECHANICAL MAINTENANCE

Item	Schedule Service	Suggested Maintenance
Gear reducer	At start-up and every month of operation	Check oil
	Yearly	Change oil
Motor	At start-up and every month of operation	Check mounting hardware and align if necessary
Drive chain	Monthly	Check tension and alignment
	Monthly	Clean and lubricate with brush or spray
Flange bearings or pillow block bearing	Monthly	Lubricate
Roller bearings	Weekly	Check for unusual noise or excessive wear, replace as required
Belt	Weekly	Inspect belt for damage, excessive wear, and tracking
		Inspect lacing for missing hooks, uneven lacing and lacings that are pulling out
Protective guards	At start-up and every week of operation	Check to ensure all guards are in place and properly secure
End pulleys	Weekly	Check to ensure pulleys are free of any obstruction, centered in the frame and aligned properly
Supports	Weekly	Check to ensure supports have not been damaged and are properly secured
Hardware	At start-up and every week of operation	Check to ensure all fasteners are in place and properly tightened

Note: Gear reduction drives units are filled with lubricant prior to shipping. The lubricant level should be checked prior to start-up and the breather plug installed in the proper location (see reducer manual supplied with unit). Only refill reducers with the approved lubricant required for standard service - if service is more severe; the oil should be changed more frequently. Consult the reducer manufacturer for a more specific lubrication schedule.

ELECTRICAL MAINTENANCE

WARNING: DISCONNECT ALL POWER BEFORE PERFORMING THE FOLLOWING MAINTENANCE. ENSURE THE MAIN POWER DISCONNECT SWITCH TO THE CONVEYOR IS LOCKED OUT IN ACCORDANCE WITH PROPER WRITTEN LOCKOUT PROCEDURES.

ONLY QUALIFIED PERSONNEL SHOULD PERFORM THE FOLLOWING MAINTENANCE.

Note: A qualified person should keep a logbook of the following readings noting and documenting any excessive changes from normal that could indicate a potential problem.

1. Measure voltages and current of incoming power to enclosure.
2. Measure current readings of all motors.
3. Measure current readings on primary and secondary of control transformer to insure proper infeed and output voltage.
4. Review usage - excessive use of fuses or replacing the same part several times indicates an excessive current draw, faulty components, or exceeding the capacity of the conveyor unit.

Item	Schedule Service	Suggested Maintenance
Control panels and pushbutton enclosures	Always	Enclosures should be clean and dry
	Weekly	Check if components have vibrated loose, check door/power interlocks and latches
	At start-up, monthly or if any problems occur	Check for loose or discolored wires (Discolored wires indicate an excessive current draw)
Photoeyes	At start-up, weekly	Dust, oil and foreign objects should be wiped from lenses and reflectors
Limit switches	Weekly	Check arms for adjustment and tightness
Pushbuttons	Weekly	Check wires and terminals for tightness
Emergency stop devices	Weekly	Check for proper operation
Conduit and conduit hangers	Monthly	Check for alignment and damage, exposed wiring
Wiring	At start-up, monthly or if any problems occur	Check for exposed cords and wires for damage, replace as necessary

TROUBLE SHOOTING GUIDES

MOTOR AND GEAR REDUCER

Problem	Possible Cause	Suggested Solution
Hard to start, stalling out or running hot	Drag on conveyor	Inspect for obstruction causing drag and remove
	Lack of lubricant	Check oil level in gearbox, verify vent breather plug is open
	Overloaded	Remove load and possibly increase horsepower
	Electrical	Check wiring, circuits and take load readings
Excessive noise	Lack of lubricant	Check oil level in reducer and add if required
	Damaged gears	Replace unit
	Faulty bearing	Replace bearing

CHAIN AND SPROCKETS

Problem	Possible Cause	Suggested Solution
Abnormal wear	Excessive chain tension	Reduce the chain tension
	Misaligned sprockets	Align sprocket faces using a straight edge and tighten set screws
	Chain not lubricated	Lubricate with proper lubricant
	Damaged chain or sprocket	Replace damaged component
	Misaligned chain guard	Adjust as required
Excessive noise	Loose chain	Adjust chain tension
	Chain not lubricated	Lubricate with proper lubricant
	Misaligned sprockets	Align sprocket faces using a straight edge and tighten set screws
Pulsating chain	Improper chain tension	Adjust chain tension
	Overloaded conveyor	Inspect for obstruction causing drag or remove excess load
Broken chain	Seized or sticking pulley, sprocket or shaft	Inspect and replace damaged items
	Worn or damaged chain	Replace damaged chain
	Obstruction	Inspect conveyor for obstruction and remove
Sprockets loose on shaft	Loose setscrews	Align sprocket faces using a straight edge and tighten set screws
	Worn or damaged key	Replace key and inspect shaft keyway for damage
Chain slack	Normal wear	Adjust chain to proper tension or replace chain

ELECTRICAL

Problem	Possible Cause	Suggested Solution
Motor not operating	Emergency stop activated	Reset pull cord, air pressure switch or pushbuttons
	Blown fuses	If resistance from hot to ground is OK replace fuse
	Overload relay tripped	Reset relay, measure current draw
	Check for wiring problems	Check wiring diagram for correct connections
Unit running wrong direction	3 phase motor wired incorrectly	Check proper voltage wiring diagram
	1 phase motor wired incorrectly	Check proper voltage wiring diagram
	DC motor wired incorrectly	Check proper voltage wiring diagram
Overload relay trips	Check setting on overload relay with full load amperage on motor nameplate	If incorrect, reset overload relay
	Check for mechanical binding or jams	Remove item creating drag load on unit - check belt
	Additional load is too much for motor	Decrease the amount of product load on unit
	Check if motor current draw is high	Drive may require more horsepower-consult factory
Unit operates sporadically	Check photoeyes	Clean lens and check for proper alignment
	Check reflectors	Clean and check for proper alignment
	Limit switches	Check arm location and tightness
	Solenoids	Check pressure at the valve
	Loose connections	Check wire nuts and terminal strip

BELT

Problem	Possible Cause	Suggested Solution
Belt stopped or moving slower than normal	Chain loose and is skipping teeth	Tension chain. Check sprocket alignment, check for worn teeth
	Belt has separated	Replace the entire belt or cut out damaged portion
	Bearings have failed	Locate and replace bad bearings
	Belt jammed due to obstruction	Check belt path and remove any obstruction
Belt slipping on drive pulley	Take-up not adjusted properly	Adjust take-up bolts in small increments
	Drive pulley lagging or pulley side of belt is slippery	Replace unit
	Load too heavy	Remove as required
Belt runs to one side	Roller or frame not square	Check alignment of pulleys, rollers and conveyor beds
	Conveyor not level	Level conveyor bed
	Pulley bearing setscrews loose	Loosen belt and reposition the pulley, centering it in the frame. Retighten setscrews

DO NOT ATTEMPT MAINTENANCE ON ANY CONVEYOR WHILE IT IS IN OPERATION. DISCONNECT ALL POWER WHILE PERFORMING ANY MAINTENANCE FUNCTIONS ENSURING THAT THE MAIN POWER DISCONNECT SWITCH TO THE CONVEYOR IS LOCKED OUT IN ACCORDANCE WITH PROPER WRITTEN LOCKOUT PROCEDURES.

PARTS GUIDE

DRIVE PULLEY

4" DIAMETER x 1" SHAFT (nominal bed width)	PART NUMBER
12"	4ED-120
18"	4ED-180
24"	4ED-240
30"	4ED-300
4" DIAMETER x 1-3/16" SHAFT (nominal bed width)	PART NUMBER
36"	4ED-360
6" DIAMETER x 1-3/16" SHAFT (nominal bed width)	PART NUMBER
12"	6ED-120
18"	6ED-180
24"	6ED-240
30"	6ED-300
36"	6ED-360
8" DIAMETER x 1-3/16" SHAFT (nominal bed width)	PART NUMBER
12"	8ED-120
18"	8ED-180
24"	8ED-240
30"	8ED-300
36"	8ED-360

IDLER PULLEY

4" DIAMETER x 1" SHAFT (nominal bed width)	PART NUMBER
12"	4ED-121
18"	4ED-181
24"	4ED-241
30"	4ED-301
4" DIAMETER x 1-3/16" SHAFT (nominal bed width)	PART NUMBER
36"	4ED-361
6" DIAMETER x 1-3/16" SHAFT (nominal bed width)	PART NUMBER
12"	6ED-121
18"	6ED-181
24"	6ED-241
30"	6ED-301
36"	6ED-361
8" DIAMETER x 1-3/16" SHAFT (nominal bed width)	PART NUMBER
12"	8ED-121
18"	8ED-181
24"	8ED-241
30"	8ED-301
36"	8ED-361

8" DRIVE PULLEY (FOR CENTRE DRIVE ASSEMBLY)

8" DIAMETER x 1-3/16" SHAFT (nominal bed width)	PART NUMBER
12"	8CD-120
18"	8CD-180
24"	8CD-240
30"	8CD-300
36"	8CD-360

TAKE UP ROLLER (FOR CENTRE DRIVE ASSEMBLY)

4" DIAMETER x 1-3/16" SHAFT (nominal bed width)	PART NUMBER
12"	4TU-120
18"	4TU-180
24"	4TU-240
30"	4TU-300
36"	4TU-360
6" DIAMETER x 1-3/16" SHAFT (nominal bed width)	PART NUMBER
12"	6TU-120
18"	6TU-180
24"	6TU-240
30"	6TU-300
36"	6TU-360

SNUBBER ROLLERS (FOR BELT ON ROLLER DRIVE BED)

2-1/2" DIAMETER x 11 GAUGE (nominal bed width)	PART NUMBER
12"	2511-090-H
18"	2511-150-H
24"	2511-210-H
30"	2511-270-H
36"	2511-330-H

CARRIER ROLLERS

1.9" DIAMETER x 16 GAUGE (nominal bed width)	PART NUMBER
12"	1916-09
18"	1916-15
24"	1916-21
30"	1916-27
36"	1916-33

BELT RETURN ROLLERS

1.9" DIAMETER x 16 GAUGE (nominal bed width)	PART NUMBER
12"	1916-09SA
18"	1916-15SA
24"	1916-21SA
30"	1916-27SA
36"	1916-33SA

BEARINGS

COMPONENT	PART NUMBER
2 Bolt flange bearing 1" bore	UCFL-205-16
2 Bolt flange bearing 1-3/16" bore	UCFL-206-19
Pillow block bearing 1-3/16" bore	UCP-206-19

BELTING / LACING

TYPE	STANDARD SPECIFICATION
Friction Friction	FD150FF
Rough Top	R2BRT
PVC	PB120COS
Lacing for belts 1/16" to 1/8" thick	Clipper # 1
Lacing for belts 1/8" to 3/16" thick	Clipper # 2
Lacing for belts over 3/16" thick	Clipper # 3

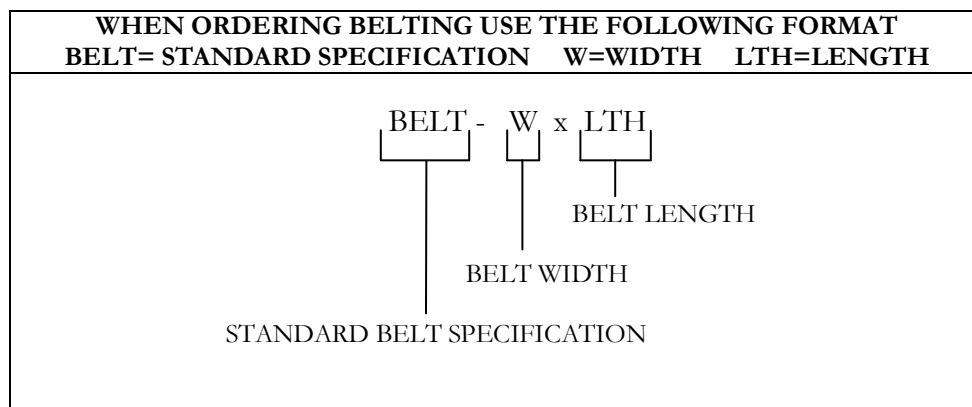

DRIVE TRAIN PARTS

COMPONENT	PART NUMBER
50B12 to 50B30 sprockets	Refer to drive train identification charts
RC 50 chain	RC-50-R1 x length
RC 50 connecting link	RC-50-CL
RC 50 offset link	RC-50-OL

MOTOR / REDUCER / SPROCKETS

DRIVE TRAIN IDENTIFICATION CHART				4" End Drive	
Nominal Speed F.P.M.	H.P.	Gearbox Size Ratio: 1		Sprocket Driver 50B__	Sprocket Driven 50B__
30	1/2	CC60	60	14 x 1	15 x 1
30	3/4	CC70	60	14 x 1-1/8	15 x 1
30	1	CC70	60	14 x 1-1/8	15 x 1
30	1-1/2	CC100	60	16 x 1-1/2	18 x 1
45	1/2	CC60	40	14 x 1	16 x 1
45	3/4	CC60	40	14 x 1	16 x 1
45	1	CC70	40	14 x 1-1/8	16 x 1
45	1-1/2	CC80	40	14 x 1-3/8	16 x 1
60	1/2	CC60	30	15 x 1	17 x 1
60	3/4	CC60	30	15 x 1	17 x 1
60	1	CC60	30	15 x 1	17 x 1
60	1-1/2	CC70	30	15 x 1-1/8	17 x 1
75	1/2	CC60	20	14 x 1	19 x 1
75	3/4	CC60	20	14 x 1	19 x 1
75	1	CC60	20	14 x 1	19 x 1
75	1-1/2	CC60	20	14 x 1	19 x 1
90	1/2	CC60	20	14 x 1	15 x 1
90	3/4	CC60	20	14 x 1	15 x 1
90	1	CC60	20	14 x 1	15 x 1
90	1-1/2	CC60	20	14 x 1	15 x 1
120	1/2	CC60	15	14 x 1	16 x 1
120	3/4	CC60	15	14 x 1	16 x 1
120	1	CC60	15	14 x 1	16 x 1
120	1-1/2	CC60	15	14 x 1	16 x 1
180	1/2	CC60	10	14 x 1	16 x 1
180	3/4	CC60	10	14 x 1	16 x 1
180	1	CC60	10	14 x 1	16 x 1
180	1-1/2	CC60	10	14 x 1	16 x 1

DRIVE TRAIN IDENTIFICATION CHART					6" End Drive	
Nominal Speed F.P.M.	H.P.	Gearbox Size Ratio: 1		Sprocket Driver 50B__	Sprocket Driven 50B__	
30	1/2	CC60	60	14 x 1	23 x 1-3/16	
30	3/4	CC70	60	14 x 1-1/8	23 x 1-3/16	
30	1	CC70	60	14 x 1-1/8	23 x 1-3/16	
30	1-1/2	CC100	60	16 x 1-1/2	26 x 1-3/16	
45	1/2	CC60	40	14 x 1	23 x 1-3/16	
45	3/4	CC60	40	14 x 1	23 x 1-3/16	
45	1	CC70	40	14 x 1-1/8	23 x 1-3/16	
45	1-1/2	CC80	40	14 x 1-3/8	23 x 1-3/16	
60	1/2	CC60	30	14 x 1	23 x 1-3/16	
60	3/4	CC60	30	14 x 1	23 x 1-3/16	
60	1	CC60	30	14 x 1	23 x 1-3/16	
60	1-1/2	CC70	30	14 x 1-1/8	23 x 1-3/16	
75	1/2	CC60	20	14 x 1	28 x 1-3/16	
75	3/4	CC60	20	14 x 1	28 x 1-3/16	
75	1	CC60	20	14 x 1	28 x 1-3/16	
75	1-1/2	CC60	20	14 x 1	28 x 1-3/16	
90	1/2	CC60	20	14 x 1	23 x 1-3/16	
90	3/4	CC60	20	14 x 1	23 x 1-3/16	
90	1	CC60	20	14 x 1	23 x 1-3/16	
90	1-1/2	CC60	20	14 x 1	23 x 1-3/16	
120	1/2	CC60	15	14 x 1	23 x 1-3/16	
120	3/4	CC60	15	14 x 1	23 x 1-3/16	
120	1	CC60	15	14 x 1	23 x 1-3/16	
120	1-1/2	CC60	15	14 x 1	23 x 1-3/16	
180	1/2	CC60	10	14 x 1	23 x 1-3/16	
180	3/4	CC60	10	14 x 1	23 x 1-3/16	
180	1	CC60	10	14 x 1	23 x 1-3/16	
180	1-1/2	CC60	10	14 x 1	23 x 1-3/16	

DRIVE TRAIN IDENTIFICATION CHART				8" End & Centre Drive	
Nominal Speed F.P.M.	H.P.	Gearbox Size Ratio: 1		Sprocket Driver 50B__	Sprocket Driven 50B__
30	1/2	CC60	60	12 x 1	26 x 1-3/16
30	3/4	CC70	60	12 x 1-1/8	26 x 1-3/16
30	1	CC70	60	12 x 1-1/8	26 x 1-3/16
30	1-1/2	CC100	60	N/A	N/A
45	1/2	CC60	40	14 x 1	30 x 1-3/16
45	3/4	CC60	40	14 x 1	30 x 1-3/16
45	1	CC70	40	14 x 1-1/8	30 x 1-3/16
45	1-1/2	CC80	40	14 x 1-3/8	30 x 1-3/16
60	1/2	CC60	30	14 x 1	30 x 1-3/16
60	3/4	CC60	30	14 x 1	30 x 1-3/16
60	1	CC60	30	14 x 1	30 x 1-3/16
60	1-1/2	CC70	30	14 x 1-1/8	30 x 1-3/16
75	1/2	CC60	20	11 x 1	30 x 1-3/16
75	3/4	CC60	20	11 x 1	30 x 1-3/16
75	1	CC60	20	11 x 1	30 x 1-3/16
75	1-1/2	CC60	20	11 x 1	30 x 1-3/16
90	1/2	CC60	20	12 x 1	26 x 1-3/16
90	3/4	CC60	20	12 x 1	26 x 1-3/16
90	1	CC60	20	12 x 1	26 x 1-3/16
90	1-1/2	CC60	20	12 x 1	26 x 1-3/16
120	1/2	CC60	15	14 x 1	30 x 1-3/16
120	3/4	CC60	15	14 x 1	30 x 1-3/16
120	1	CC60	15	14 x 1	30 x 1-3/16
120	1-1/2	CC60	15	14 x 1	30 x 1-3/16
180	1/2	CC60	10	14 x 1	30 x 1-3/16
180	3/4	CC60	10	14 x 1	30 x 1-3/16
180	1	CC60	10	14 x 1	30 x 1-3/16
180	1-1/2	CC60	10	14 x 1	30 x 1-3/16

SUPPORTS

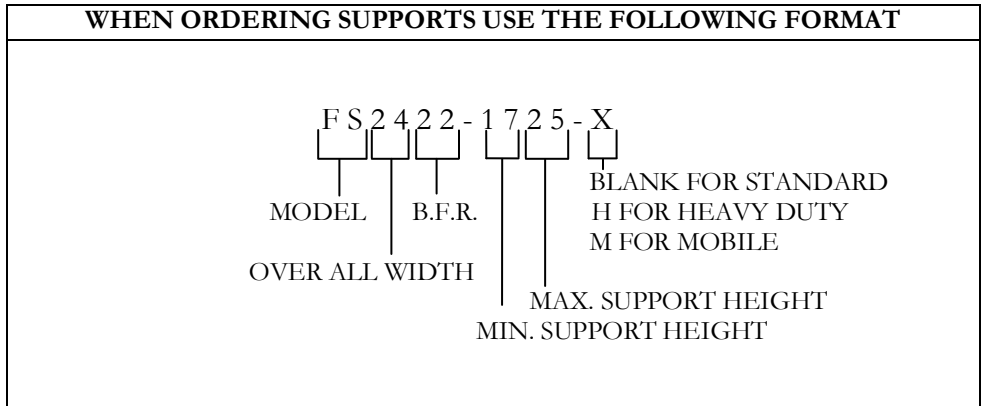

FORMED ANGLE GUARD RAILS

TYPE	PART NUMBER
1" x 1" x 120" long	FAGR-11-120
1" x 3" x 120" long	FAGR-13-120
1" x 6" x 120" long	FAGR-16-120
Nylon protective cap strip	40-106

TOUCH-UP PAINT

COLOUR	PART NUMBER
Wecon (shop) blue	P-S-BLUE
Ermanco blue (ER-1)	P-E-BLUE-ER-1
Ermanco blue (ER-2)	P-E-BLUE-ER-2
Medium grey	P-M-GREY
Wecon (shop) green	P-S-GREEN
Safety yellow	P-S-YELLOW